



The World Wide Leader in Antenna

GPS Antenna

XM-SRA-11



Frequency : 2338.75Mhz

Gain : 2dBi

V.S.W.R : 2 :1

Impedance : 50 ohm

Connector : SMB (Optional)

Cable : 6.4meter of RG174 (Optional)

Material : ABS

Weight : ≐ 120g

Color : Black

Polarization : Linear (H) or (V)

Mounting : Magnet Type

Amplification : 33dB

Noise Figure : 1.4dB

Voltage supply : 3.6...5.5V

Current Consumption : Max. 40mA

Temperature : -40°C to +85°C

EVERCOM COMMUNICAITON TECHNOLOGY CO., LTD.

No.108 Jiesin St. Taoyuan District Taoyuan City 33063, Taiwan R.O.C.

Tel: +886-3- 376- 5678 Fax: +886-3- 376- 5319 E-Mail: service@evercomtech.com

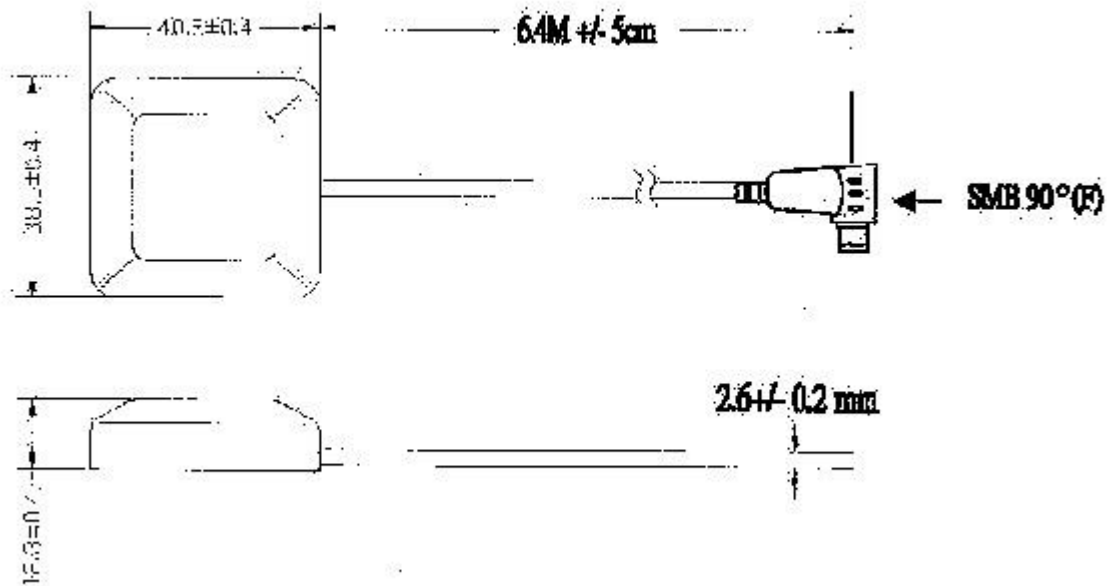

Evercom Communication Technology Co., Ltd. Frequency Inspection Report

1 Active Ch/Trace 2 Response 3 Stimulus 4 Mkr/Analysis 5 Instr State

Evercom Communication Technology Co.,Ltd.

▶ Tr1 S11 Log Mag 10.00dB/ Ref 0.000dB [R0]

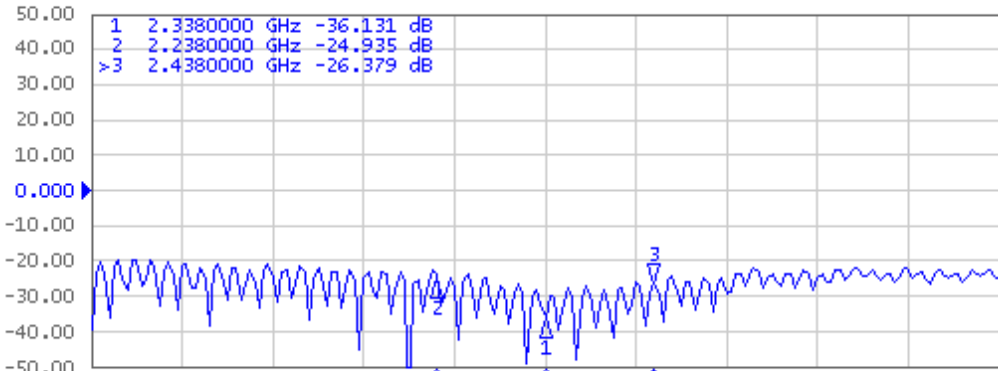

Tr2 S11 SWR 1.000/ Ref 1.000 [R0]

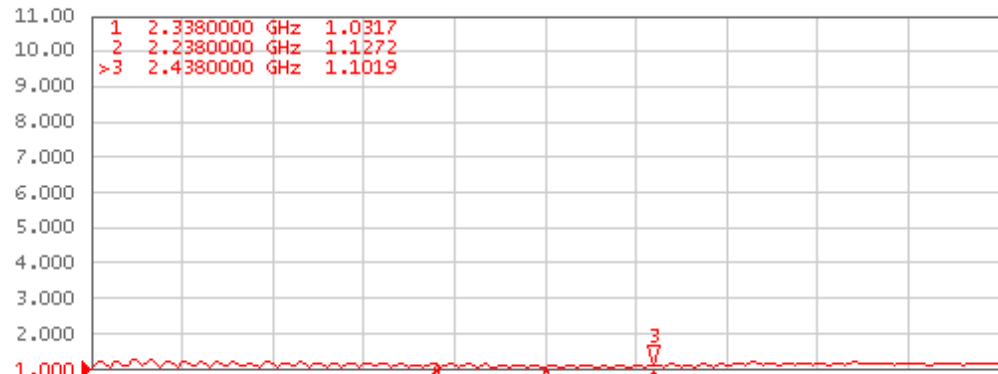

1 Center 2.338 GHz IFBW 70 kHz Span 838 MHz Cor

Meas Stop ExtRef Ready Svc 2017-06-12 10:25

Item No. RG-XM-SRA-11/RASMB-F6.4

Inspector: Amber



The World Wide Leader in Antenna

Packaging

***1 pc Antenna
PE bag/ each**

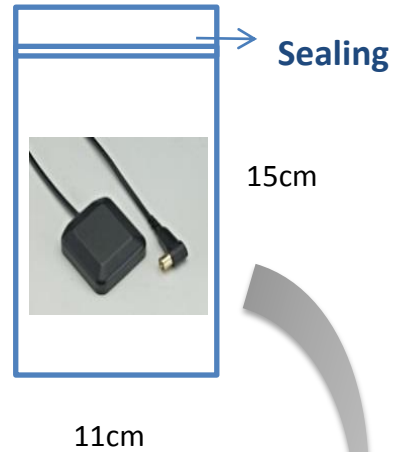

**100 pcs per carton
Carton Dimensions:37*37*30cm**

