



The World Wide Leader in Antenna

WIFI 5G Antenna

UWB-PANEL-518



Frequency : 5.10 - 5.90GHz

Gain : 18dBi

V.S.W.R : <1.5:1

Impedance : 50 ohm

Connector : N Female

Material : ABS Polymer

Dimension : 276 x276 x70mm

Weight : ≐ 800g

Color : Gray

Polarization : Linear (V) or (H)

Mount : AC-PHOLD / KIT

Wind Load : 120km/h

Max Power : 20W

Horizontal Beam width : 16 degree

Vertical Beam width : 16 degree

Temperature : -40°C to +80°C

EVERCOM COMMUNICAITON TECHNOLOGY CO., LTD.

No.108 Jiesin St. Taoyuan District Taoyuan City 33063, Taiwan R.O.C.

Tel: +886-3- 376- 5678 Fax: +886-3- 376- 5319 E-Mail: service@evercomtech.com



ISO 9001

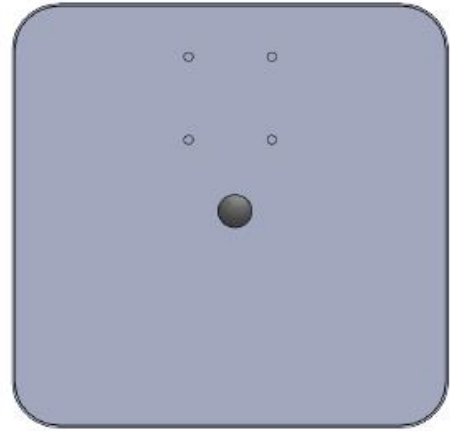
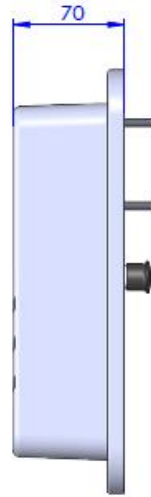
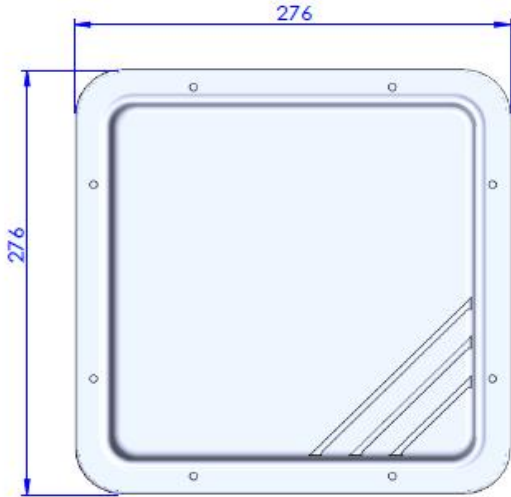
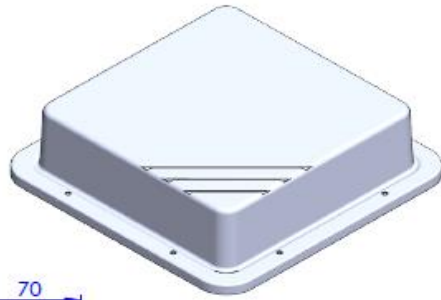

EVERCOM COMMUNICATION TECHNOLOGY CO; LTD

CHECKED BY

APPROVAL BY

DESIGNED BY

SCALE

UNIT

MODEL NO.

PANEL-518NF

Y.W.C

1:2

mm

2021.12.08

1 Active Ch/Trace 2 Response 3 Stimulus 4 Mkr/Analysis 5 Instr State

Tr1 S11 Log Mag 10.00dB/ Ref 0.000dB [R0]

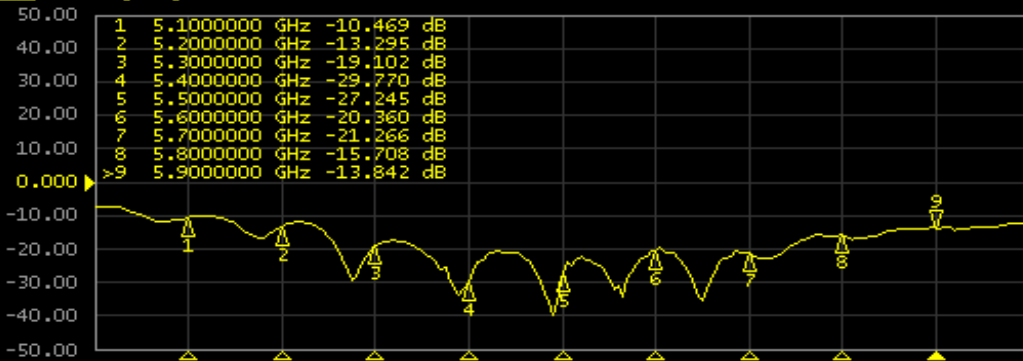

Tr2 S11 SWR 1.000/ Ref 1.000 [R0]

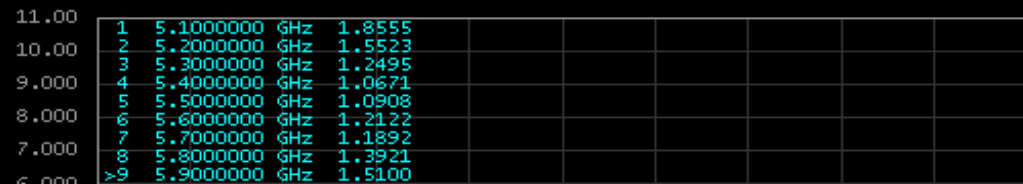

1 Center 5.5 GHz

IFBW 70 kHz

Span 1 GHz

Cor

System

Print

Abort Printing

Printer Setup...

Invert Image

ON

Dump Screen Image...

Multiport Test Set Setup

Misc Setup

Backlight

ON

Firmware Revision



The World Wide Leader in Antenna

Packaging

A set of antenna put in an inner box

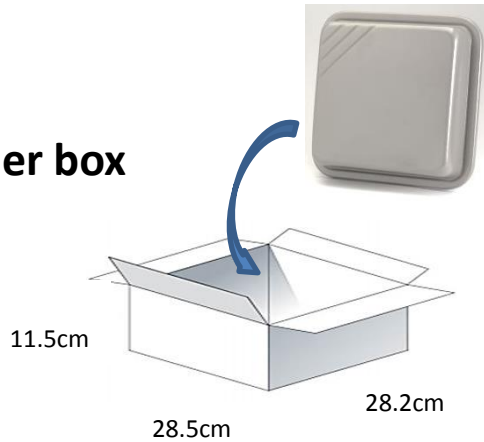

10 pcs per carton

Carton Dimensions: 63*30.3*59.1cm

